



OM-699

189 553C

May 2000

Description

Two-Wheel Trailer For Small Engine-Driven Welding Generators

HWY-210

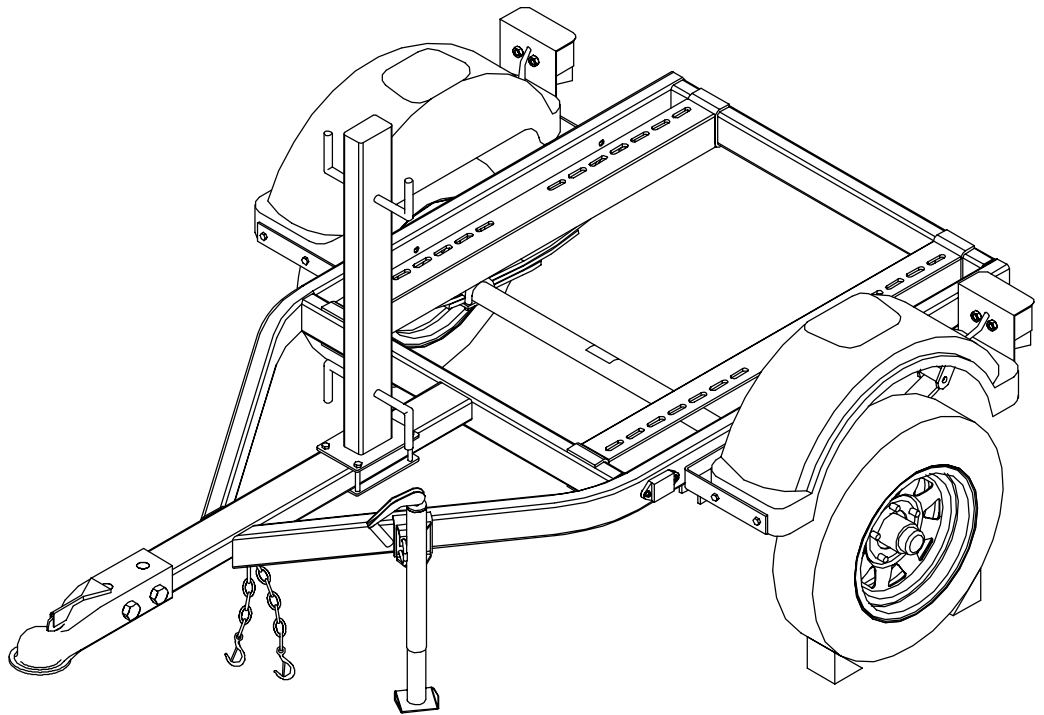

OWNER'S MANUAL



Visit our website at
www.MillerWelds.com

From Miller to You

Thank you and congratulations on choosing Miller. Now you can get the job done and get it done right. We know you don't have time to do it any other way.

That's why when Niels Miller first started building arc welders in 1929, he made sure his products offered long-lasting value and superior quality. Like you, his customers couldn't afford anything less. Miller products had to be more than the best they could be. They had to be the best you could buy.



Today, the people that build and sell Miller products continue the tradition. They're just as committed to providing equipment and service that meets the high standards of quality and value established in 1929.

This Owner's Manual is designed to help you get the most out of your Miller products. Please take time to read the Safety precautions. They will help you protect yourself against potential hazards on the worksite. We've

made installation and operation quick and easy. With Miller you can count on years of reliable service with proper maintenance. And if for some reason the unit needs repair, there's a Troubleshooting section that will help you figure out what the problem is. The parts list will then help you to decide which exact part you may need to fix the problem. Warranty and service information for your particular model are also provided.



Miller is the first welding equipment manufacturer in the U.S.A. to be registered to the ISO 9001 Quality System Standard.

Miller Electric manufactures a full line of welders and welding related equipment. For information on other quality Miller products, contact your local Miller distributor to receive the latest full line catalog or individual catalog sheets. **To locate your nearest distributor or service agency call 1-800-4-A-Miller, or visit us at www.MillerWelds.com on the web.**



Working as hard as you do – every power source from Miller is backed by the most hassle-free warranty in the business.

Miller offers a Technical Manual which provides more detailed service and parts information for your unit. To obtain a Technical Manual, contact your local distributor. Your distributor can also supply you with Welding Process Manuals such as SMAW, GTAW, GMAW, and GMAW-P.



TRAILER TOWING SAFETY PRECAUTIONS

⚠️ WARNING

TRAILER TOWING can be hazardous.

In trailer towing, as in most driving situations, exposure to certain hazards occurs. Trailer towing is safe when precautions are taken. The following safety information is only a summary of the more complete information found in the Safety Standards listed at the end of these precautions. Read and follow all Safety Standards. In addition, the end user must check and comply with all federal, state, and local laws before use.

HAVE ALL INSTALLATION, OPERATION, MAINTENANCE, AND REPAIR WORK PERFORMED ONLY BY QUALIFIED PEOPLE.

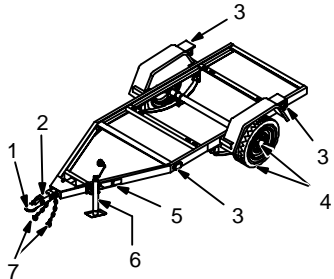

- 1 Coupler
Hitch is on towing vehicle.
- 2 Tongue
- 3 Lights
- 4 Wheels And Bearings
- 5 Rating Plate
- 6 Jack Stand
- 7 Safety Chains

1. Use a towing vehicle prepared and capable of handling the load.
2. Towing any trailer requires special awareness because of the changed driving situation.

3. When towing, it takes longer to start, stop, and pass – use training and practice to avoid accidents.
4. Turning and backing up present new problems – plan ahead.
5. Require each driver to be fully trained and experienced in trailer towing before going out on the road.
6. Holes are provided for mounting weld/power generator.
7. Be sure trailer is fully prepared and connected to towing vehicle.
8. Observe maximum speed of 45 mph (72 kph) when towing.
9. Do not modify or change the trailer in any way – changes void the warranty. Read Owner's Manual.
10. Use only genuine factory parts as replacements.
11. Adjust load on trailer so tongue weight is approximately 10% of the gross trailer weight and center load side-to-side to reduce fishtailing.
12. Tighten all parts, bolts, nuts, and mounting hardware.

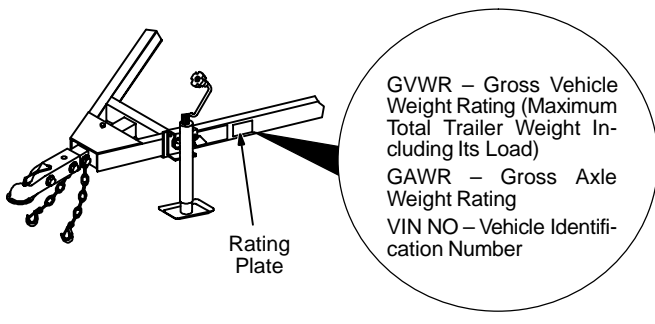

GVWR – Gross Vehicle Weight Rating (Maximum Total Trailer Weight Including Its Load)
 GAWR – Gross Axle Weight Rating
 VIN NO – Vehicle Identification Number

OVERLOADING can cause serious injury or equipment damage.

1. Do not overload the trailer.
2. The Gross Vehicle Weight Rating (GVWR) is the maximum total trailer weight with the engine driven welding generator and all equipment, such as tools, cables, and shielding gas cylinder, installed.
3. The Gross Axle Weight Rating (GAWR) is the maximum load-bearing capacity of the axle(s).
4. Weigh trailer – adjust weight by removing accessory equipment if necessary – call local authorities for nearest scale location.
5. Use gross trailer weight to select a proper towing vehicle.

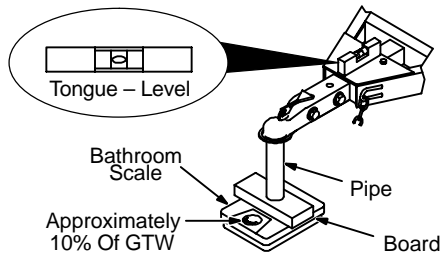

Approximately 10% Of GTW

Trailer And Coupler Class ¹	Gross Vehicle Weight Rating GVWR lb (kg)	Gross Trailer Weight GTW ² lb (kg)	Maximum Tongue Weight ³ lb (kg)
1	Up to 2000 (Up to 910)	1000 (455) 2000 (910)	100 (45) 200 (90)
2	2000 to 3500 (910 to 1590)	2000 (910) 3500 (1590)	200 (90) 350 (158)
3	3500 to 5000 (1590 to 2270)	3500 (1590)	350 (158)

¹ Information From SAE J684 May 1987
² Gross Trailer Weight (Actual Loaded Weight)
³ 10% Of GTW Recommended

UNCONTROLLED TILTING OF TRAILER can result in personal injury or equipment damage.

1. Install generator according to Owner's Manual with engine end toward hitch end of trailer.
2. Distribute weight so that trailer tongue weight is approximately 10% of the gross trailer weight.

INCORRECT TONGUE WEIGHT can cause fishtailing and loss of control of towing vehicle resulting in serious injury and equipment damage.

3. Tongue weight is the amount of trailer weight that rests on the towing vehicle hitch – that is, the downward pressure on the coupler.
4. Remove or adjust trailer load to get correct tongue weight.
5. Do not let tongue weight exceed coupler and hitch rating.
6. Use slower speeds when towing a trailer – never above 45 mph (72 km/h) – to prevent fishtailing.

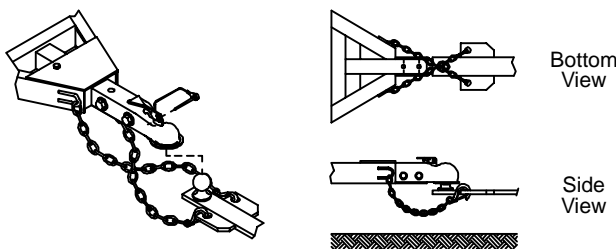

SAFETY CHAINS CAN PREVENT RUNAWAY TRAILER in case hitch/coupler fails.

1. Always use safety chains when towing.
2. Cross safety chains under coupling to prevent tongue from dropping to ground.
3. Allow only enough slack for tight turns.
4. Do not let safety chains drag on ground.
5. Twist safety chains equally from hook ends to take up slack.
6. Use safety chains rated equal to or greater than twice the maximum gross trailer weight rating.

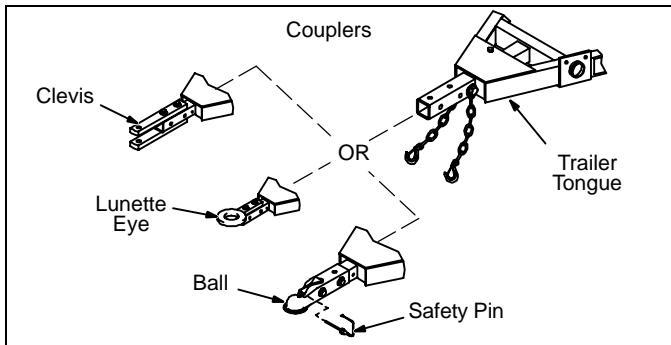

INCORRECT SIZE OR RATING OF HITCH can cause trailer to break loose from towing vehicle.

1. Be sure towing vehicle hitch is correct type, size, and rating to match coupler.
2. Be sure the hitch is properly installed onto towing vehicle.
3. On optional ball couplers, always insert hitch safety pin before towing.
4. Make sure hitch and ball are properly sized and match each other.

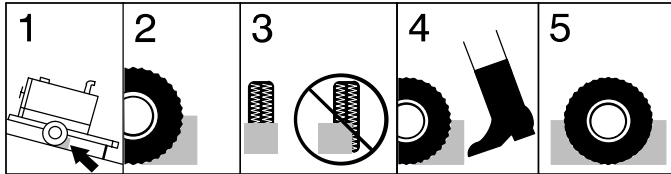

WHEELS MUST BE CHOCKED when trailer is uncoupled from vehicle.

1. Chock in direction of grade.
2. Position chock snugly behind tire.
3. Place chock square to the tire.
4. Tap chock into place.
5. For added protection, chock both sides of tire.

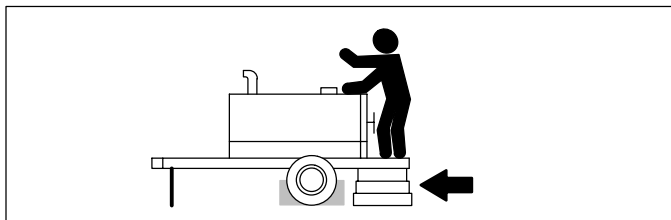

UNEXPECTED TILTING OF TRAILER can cause injury and damage.

1. When trailer is uncoupled from towing vehicle, use jack on front and block rear to prevent tilting.
2. Use proper blocks that are large enough and able to support the necessary weight.
3. Always chock the wheels when uncoupled.

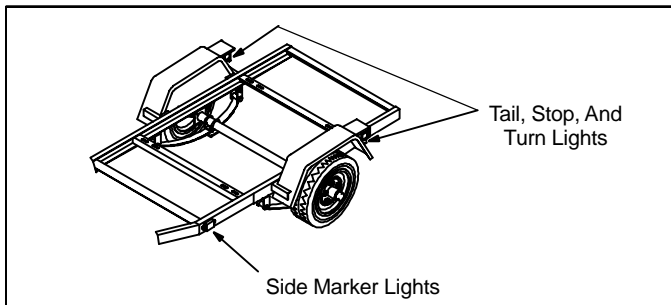

INCORRECTLY WORKING LIGHTS can cause accidents.

1. State and Federal regulations require trailers used on highways to have tail, stop, turn, and side marker lights.
2. Lights are not required for trailers designed for off-road use only.
3. Check all lights and connectors for proper installation and operation before using the trailer.
4. Check condition of wiring harness leads, plugs, and connections regularly. Repair or replace damaged parts or wires.
5. Replace any broken lenses, reflectors, or bulbs.

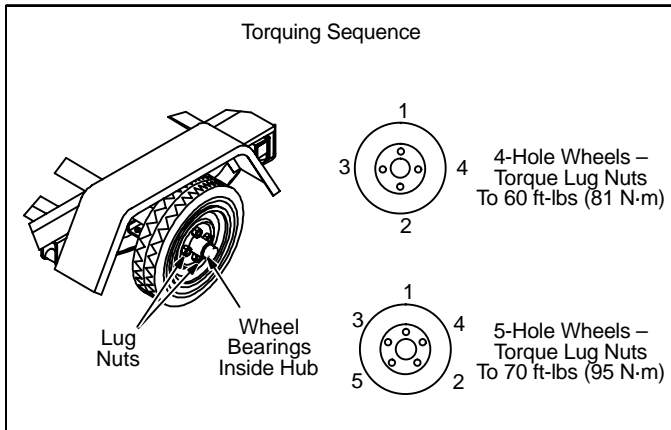

INCORRECT TORQUE on lug nuts or INCORRECT TIRE PRESSURE or BEARING MAINTENANCE can cause loss of control resulting in serious injury and equipment damage.

1. Recheck lug nut torque after first 50 miles (80 km) and once each year or every 12,000 miles (19,500 km) thereafter, whichever comes first.
2. When checking lug nuts, keep them clean, dry, and unlubricated.
3. Check and repack wheel bearings once each year or every 12,000 miles (19,500 km), whichever comes first.
4. Maintain correct tire pressure according to sidewall data on tire – underinflation is the most common cause of tire trouble.
5. Check tires for wear every six months.
6. Use only replacement tires of the same size, rating, and capacity.

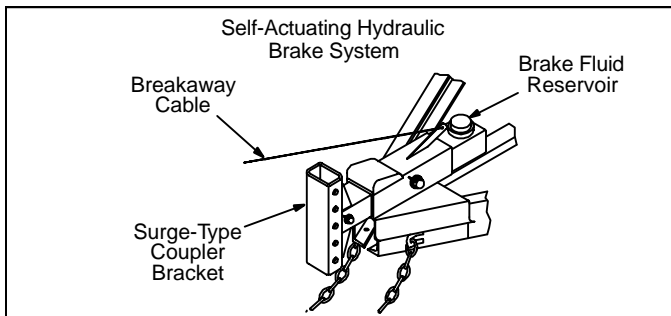

INOPERATIVE SURGE-TYPE BRAKES OR WRONG BREAKAWAY CABLE CONNECTION can cause accidents.

1. Check brake fluid level before use.
2. Do not use sway control devices – keep coupler free to telescope during braking.
3. Always connect breakaway cable to towing vehicle – be sure it has a direct free pull.
4. Do not wrap cable around safety chains, tongue, wiring, or any other parts.
5. The breakaway cable automatically applies the trailer brakes if separation occurs.

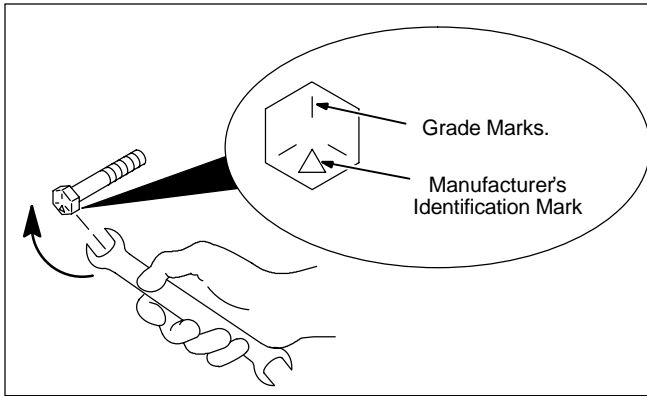

LOOSE OR INCORRECT HARDWARE AND FASTENERS can cause injury and damage.

1. Periodically double-check all nuts and bolts for tightness and condition.
2. If necessary, always replace any fastener with one of equal size, grade, and type.
3. Be sure the grade marks on replacement fastener match the original bolt. The manufacturer's identification mark is not critical and does not matter for the replacement fastener.

PRE-TOWING CHECKLIST

- Check gross trailer weight, tongue weight, and total weight distribution – do not overload this trailer.
- Check that the correct hitch is properly installed on towing vehicle.
- When coupling, check that coupler locking device (safety pin), safety chains, and breakaway cable (if applicable) are properly connected.
- Check that tires are properly inflated and that wheel nuts are properly torqued.
- If applicable, check that all lights are working properly.

PRINCIPAL SAFETY STANDARDS

Trailer & Camper Safety, Publication # DOT HS-802586, from U.S. Department of Transportation, National Highway Traffic Safety Administration, Washington, D.C. 20590

Safety and Health Standards, OSHA 49 CFR 200 to 999, from Superintendent of Documents, U.S. Government Printing Office, Washington, D.C. 20402

SAE Handbook. 1996. Volume 4. *On-Highway Vehicles and Off-Highway Machinery*, from Society of Automotive Engineers, Inc., 400 Commonwealth Drive, Warrendale, PA 15096-0001.

REPORTING SAFETY DEFECTS

If you believe that your vehicle has a defect which could cause a crash or could cause injury or death, you should immediately inform the National Highway Traffic Safety Administration (NHTSA) in addition to notifying MILLER Electric Mfg. Co.

If NHTSA receives similar complaints, it may open an investigation, and if it finds that a safety defect exists in a group of vehicles, it may order a recall and remedy campaign. However, NHTSA cannot become

involved in individual problems between you, your dealer, or MILLER Electric Mfg. Co.

To contact NHTSA, you may either call the Auto Safety Hotline toll-free at 1-800-424-9393 (or 366-0123 in Washington, D.C. area) or write to: NHTSA, U.S. Department of Transportation, Washington D.C. 20590. You can also obtain other information about motor vehicle safety from the Hotline.

mod11.1 8/94

SECTION 1 – ASSEMBLY SAFETY PRECAUTIONS

1-1. Symbol Usage



Means Warning! Watch Out! There are possible hazards with this procedure! The possible hazards are shown in the adjoining symbols.

▲ Marks a special safety message.

☞ Means "Note"; not safety related.



This group of symbols means Warning! Watch Out! possible FALLING EQUIPMENT and TILTING OF TRAILER hazards. Consult symbols and related instructions below for necessary actions to avoid the hazards.

1-2. Assembly Hazards

▲ The symbols shown below are used throughout this manual to call attention to and identify possible hazards. When you see the symbol, watch out, and follow the related instructions to avoid the hazard. The safety information given below is only a summary of the more complete safety information found in the Safety Standards. Read and follow all Safety Standards.

▲ Only qualified persons should install, operate, maintain, and repair this unit.

▲ During operation, keep everybody, especially children, away.



FALLING UNIT can cause injury.

- Use equipment and blocks of adequate capacity and size to lift and support unit.
- If using lift forks to move unit or parts, be sure forks are long enough to extend beyond opposite side of unit or parts to prevent tipping.
- Have two people of adequate physical strength lift trailer parts.

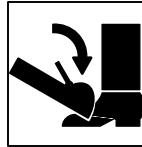

TILTING OF TRAILER can cause injury.

- Use tongue jack or blocks to support weight.
- Properly install welding generator onto trailer according to instructions.

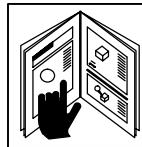

READ INSTRUCTIONS.

- Use only genuine replacement parts from manufacturer.
- Perform maintenance according to this manual.

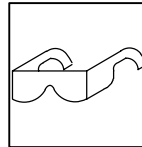

FLYING METAL, DIRT can injure eyes.

- Wear approved safety glasses with side shields when assembling and maintaining trailer.



Read and follow all trailer towing Safety Precautions at beginning of manual before using this trailer.

SECTION 2 – SPECIFICATIONS

2-1. Trailer Specifications

Specification	Description
Gross Axle Weight Rating	1500 lb (680 kg)
Gross Vehicle Weight Rating	1610 lb (730 kg)
Net Payload	1350 lb (612 kg)
Road Clearance	6-1/2 in (165 mm)
Height Of Bed	18-1/2 in (470 mm)
Standard Tires	4.8 – 12
Weight	Net: 265 lb (120 kg)

2-2. Overall Dimensions

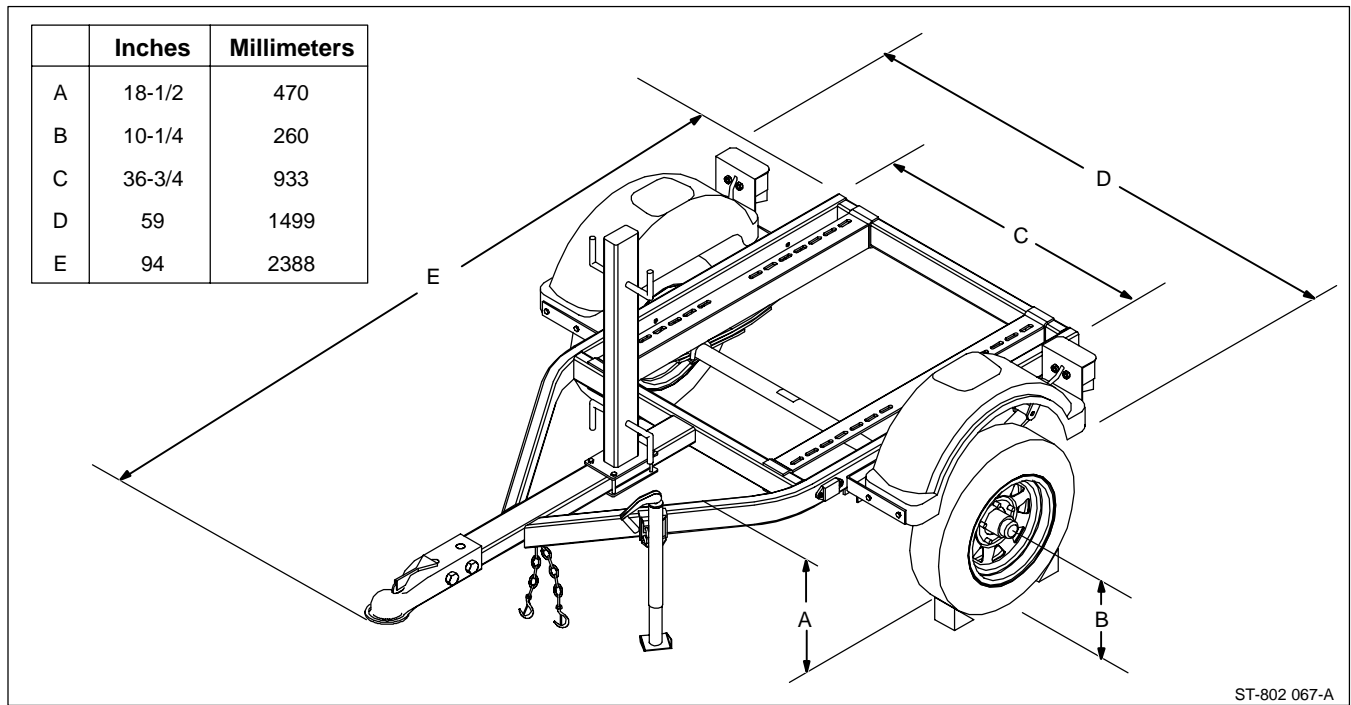

SECTION 3 – ASSEMBLY

NOTE



All directions are given as facing the towing vehicle. The word “front” means the hitch end of the trailer.

3-1. Assembling Axle And Springs



The axle has a slight camber (arch) to help the tires wear properly when the trailer is loaded. With no load on the trailer the tires appear to tilt outward. When the trailer is loaded, the tires straighten out and wear evenly.

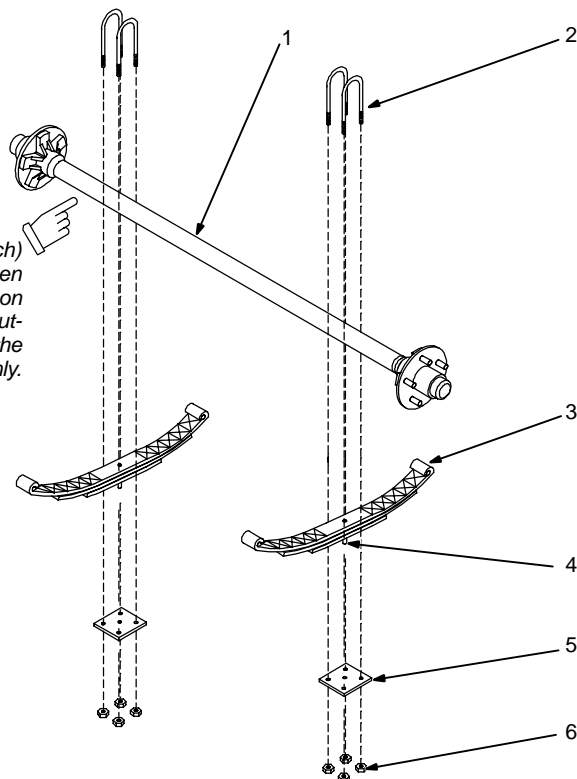

Use hardware in orange bag to assemble axle and springs.

- 1 Axle
- 2 U-Bolt
- 3 Leaf Spring
- 4 Spring Center Bolt
- 5 Spring Plate
- 6 Nut

Assemble components as shown.

Be sure the spring eyes point up and the spring center bolt is in the hole of the spring plate.

Cross-tighten hardware so plate is installed evenly. Torque hardware to 55 ft lb (74 N·m).

Tools Needed:

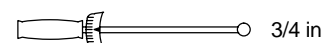

802 529

3-2. Assembling Trailer

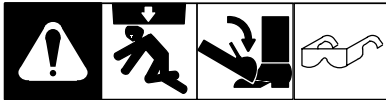

Tools Needed:

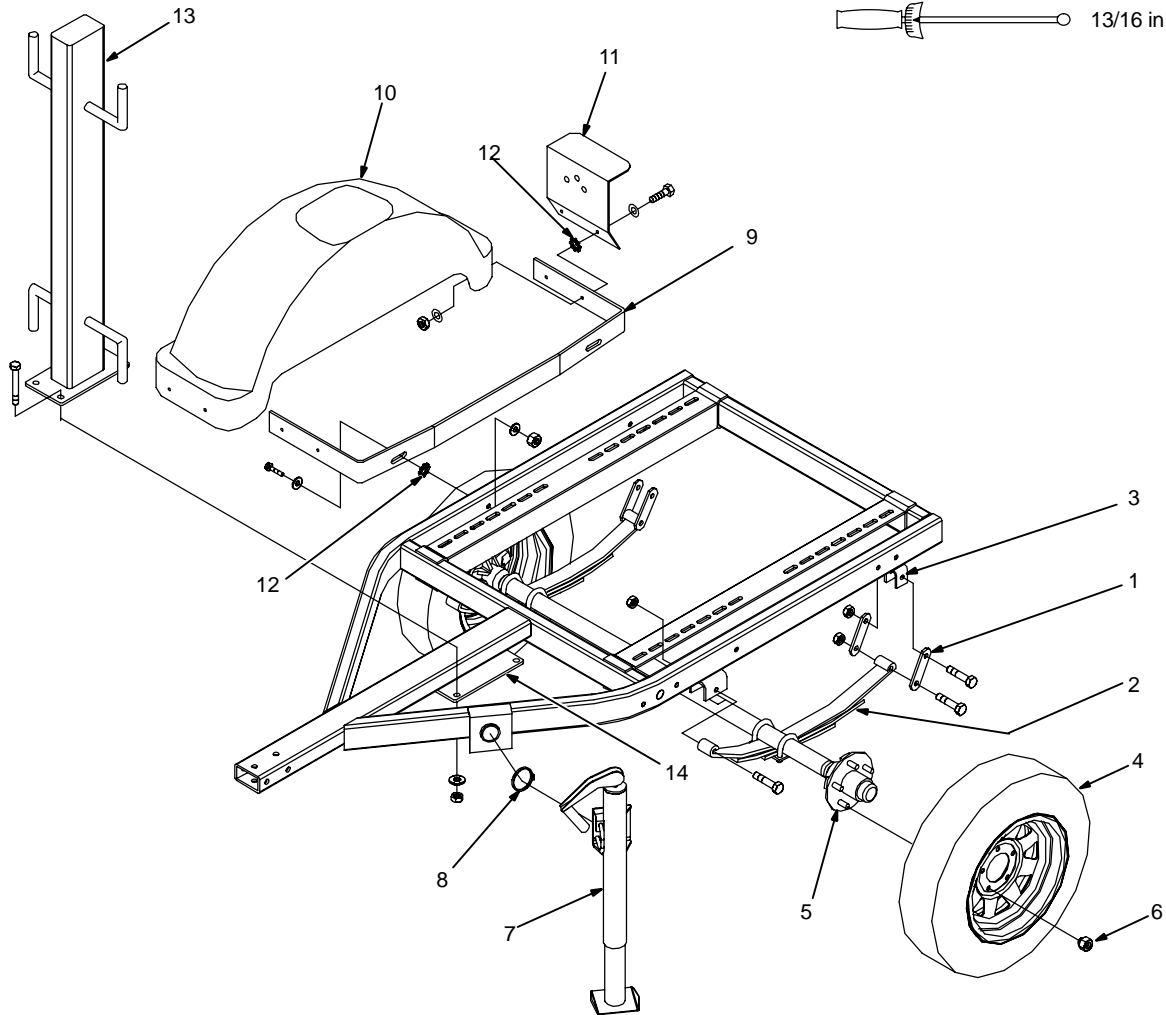
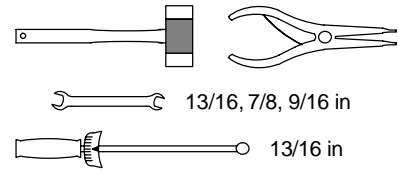

Ref. ST-802 073-A

▲ Use adequate blocks or lifting device to support frame while installing parts.

☞ Use hardware in red bag to mount axle and wheels. Use hardware in green bag to mount fenders.

- 1 Shackle Arm
- 2 Spring

Attach shackle arms to springs using 9/16 inch hardware. Tighten hardware to 50 ft lb (67 N·m) maximum.

☞ Do not overtighten shackle arm hardware. Parts must rotate freely.

- 3 Shackle Bracket

☞ Install axle assembly with axle label facing front or rear of trailer.

Attach axle assembly to brackets on frame using 9/16 inch hardware. Tighten hardware to 50 ft lb (67 N·m) maximum.

☞ Do not overtighten spring and shackle arm hardware. Parts must rotate freely.

- 4 Wheel
- 5 Hub
- 6 Lug Nut

Install wheels on hubs. Tighten lug nuts to 70 ft lb (95 N·m). Block wheels.

- 7 Jack

- 8 Snap Ring

Slide jack over collar. Use snap ring pliers to secure jack with snap ring.

Pull pin and rotate jack to vertical position. Pin locks jack in place. Turn handle to raise or lower trailer.

When jack is not needed, pull pin and rotate jack to horizontal position.

- 9 Fender Bracket

☞ Install bracket with top angling in (toward fender).

- 10 Fender
- 11 Light Bracket
- 12 Star Washer

Mount fender brackets, light brackets, and fenders on trailer using supplied 3/8 inch hardware. Be sure to install star washers between light brackets and fenders, and between fender brackets and frame.

- 13 Cable Tree (Optional)

- 14 Cable Tree Mounting Bracket

Mount cable tree on trailer using supplied hardware.

3-3. Installing Hitch And Safety Chains

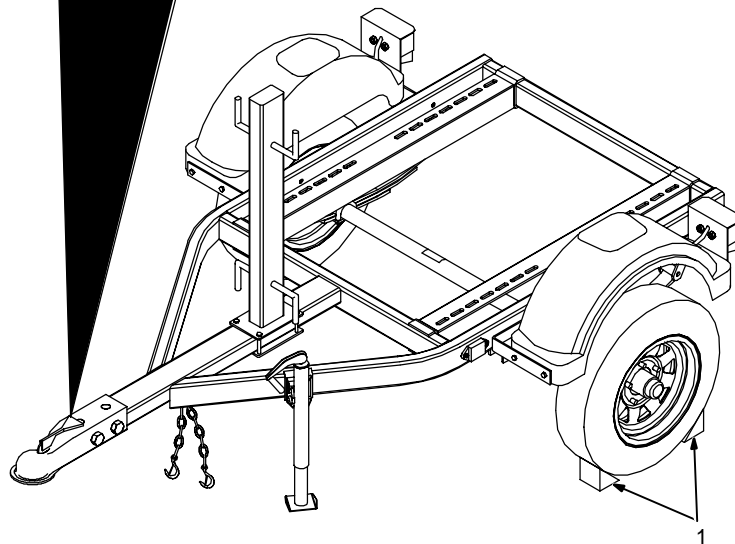
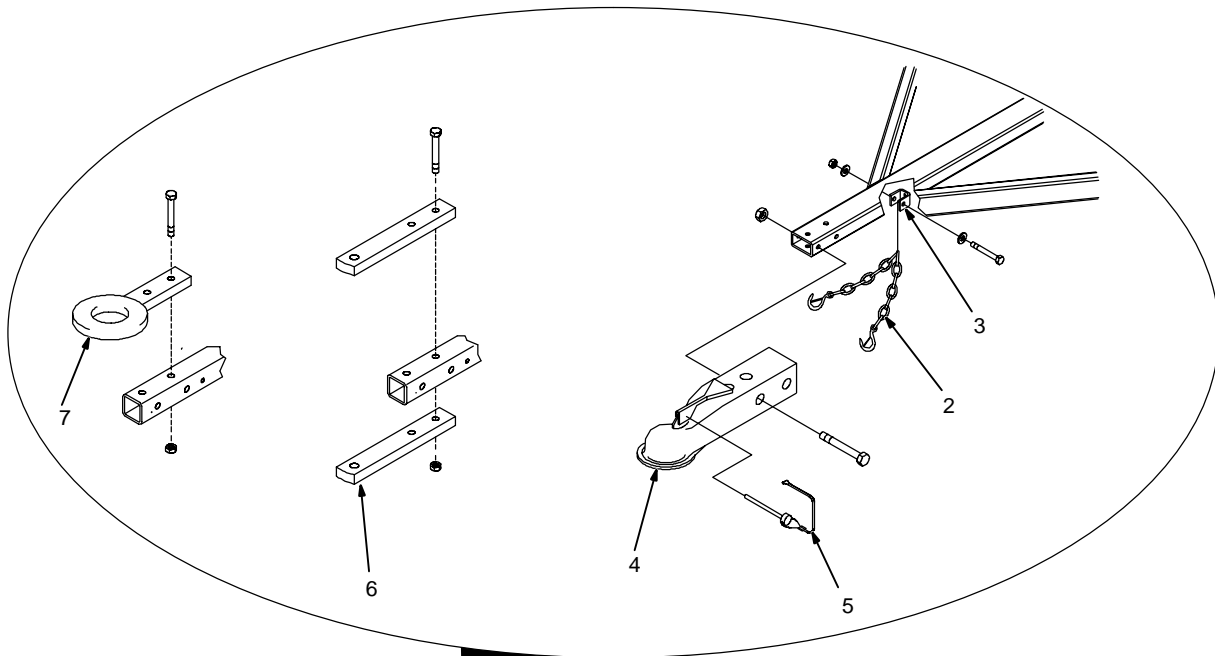
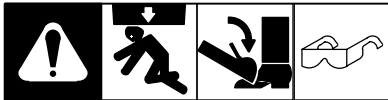

Tools Needed:

 5/8, 3/4 in

 11/16, 3/4 in

ST-802 067-B / Ref. ST-802 067-B

▲ **Use adequate blocks or lifting device to support frame while installing parts.**

▲ **Support trailer with jack. Block wheels.**

 **Use hardware in blue bag to mount safety chain.**

1 Wheel Block

Block wheels.

2 Safety Chain

3 Chain Bracket

Attach chain to bracket with 7/16 in hardware. Tighten hardware to 31 ft lb (40 N·m).

4 Ball Hitch

5 Safety Pin

Attach hitch to tongue using 1/2 in hardware (2 required). Make sure bolt is installed horizontally as shown.

Tighten hardware to 75 ft lb (102 N·m).

Set trailer onto towing ball and push lever down. Insert safety pin through hole in lever to secure hitch.

6 Clevis Hitch (Optional)

Attach bars to top and bottom of tongue using 1/2-13 x 4-1/2 in hardware (2 required).

7 Lunette Eye Hitch (Optional)

Attach lunette eye to top of tongue using 1/2-13 x 3-1/2 in hardware (2 required).

Cross safety chains under tongue and attach to towing vehicle.

3-4. Installing Light Kit

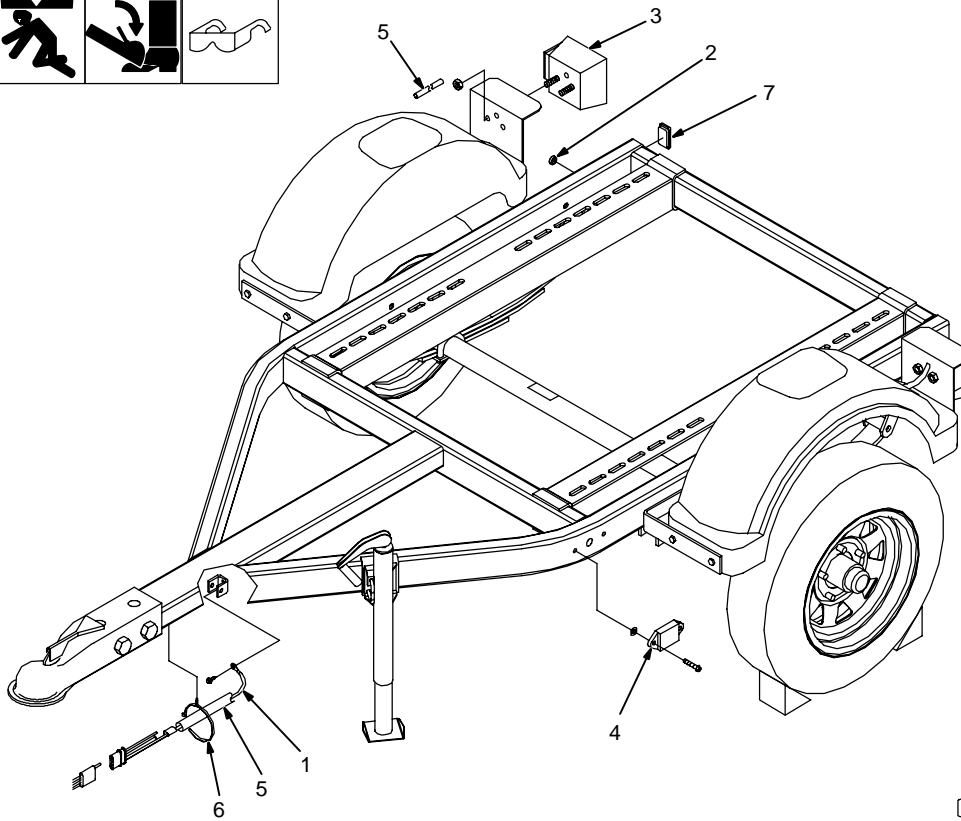
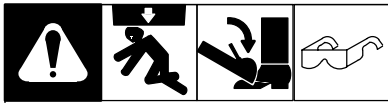

Tools Needed:

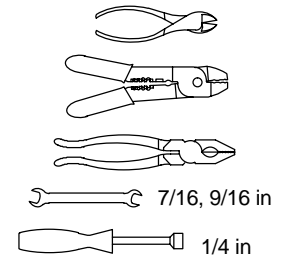

Wiring Connections:

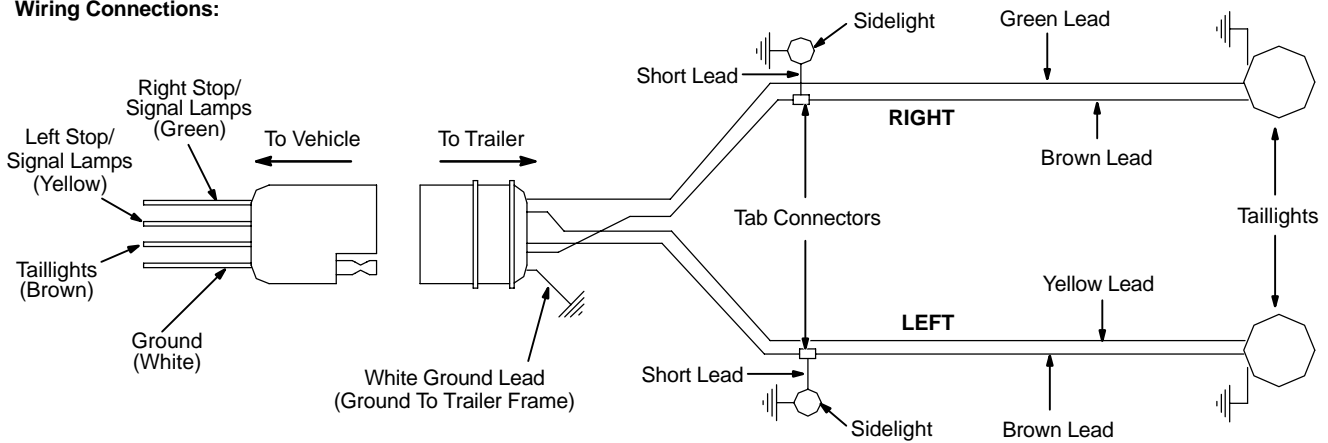

ST-802 074-A

▲ **Support trailer with jack. Block wheels.**

☞ *Use hardware in green bag to install lights.*

☞ *Use supplied wire to route harness leads through trailer frame.*

1 Wiring Harness White Ground Lead

Strip insulation from end of white ground lead and crimp on supplied ring terminal. Attach ground lead ring terminal to chain bracket using 3/4 in sheet metal screw.

Locate holes for routing wire near each taillight.

Route brown and green leads inside of right frame to exit hole. Route brown and yellow leads inside left side.

2 Grommet

Route leads through grommets. Install grommets in holes in trailer frame.

Strip 1/2 in (12.7 mm) insulation from ends of brown, green, and yellow leads.

3 Taillight

Insert stripped end of green lead into right taillight hole marked STOP & TURN (GREEN). Insert stripped end of yellow lead into left taillight hole marked STOP & TURN (YELLOW). Insert stripped end of brown leads into TAIL (BROWN) holes in each light.

Mount lights on brackets using supplied 1/4 in nuts.

4 Sidelight

Pull a small length of brown lead thru hole in side of trailer.

Splice sidelight short lead to wiring harness brown lead using supplied tab connector (see Section 3-5).

Mount sidelight on frame using supplied self-tapping screws.

Install other sidelight the same way.

5 Sleeving

Install sleeving on taillight and harness plug electrical leads.

6 Hanging Cable Tie

Install cable tie in 1/4 in (6 mm) hole in bottom of tongue. Use tie to secure harness and sleeving.

7 End Cap

Install caps in end of trailer.

3-5. Installing Wiring Harness Tab Connectors

NOTE

Disconnect vehicle wiring harness plug from trailer wiring connector before beginning installation. Use wiring harness tab connectors only with insulated wires.

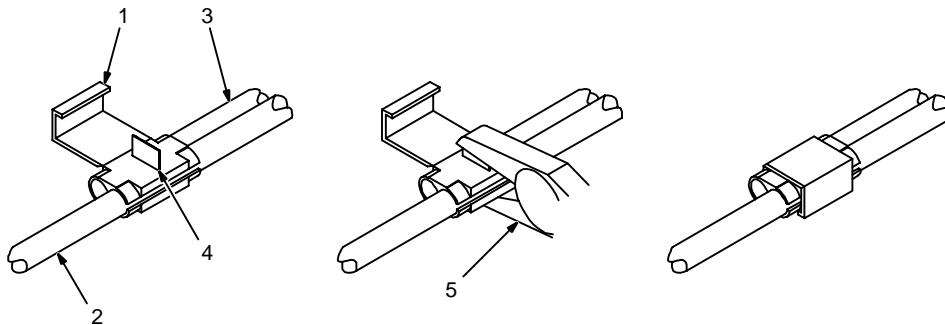

1 Connector

2 Run Wire

3 Tap Wire

Place unstripped run wire in slotted channel.

Insert unstripped tap wire into other channel until it hits internal stop.

4 Contact

5 9 Inch Linemans Pliers

Use pliers to push contact down flush with top of connector.

Close top cover.

Ref. S-0448

3-6. Installing Welding Generator

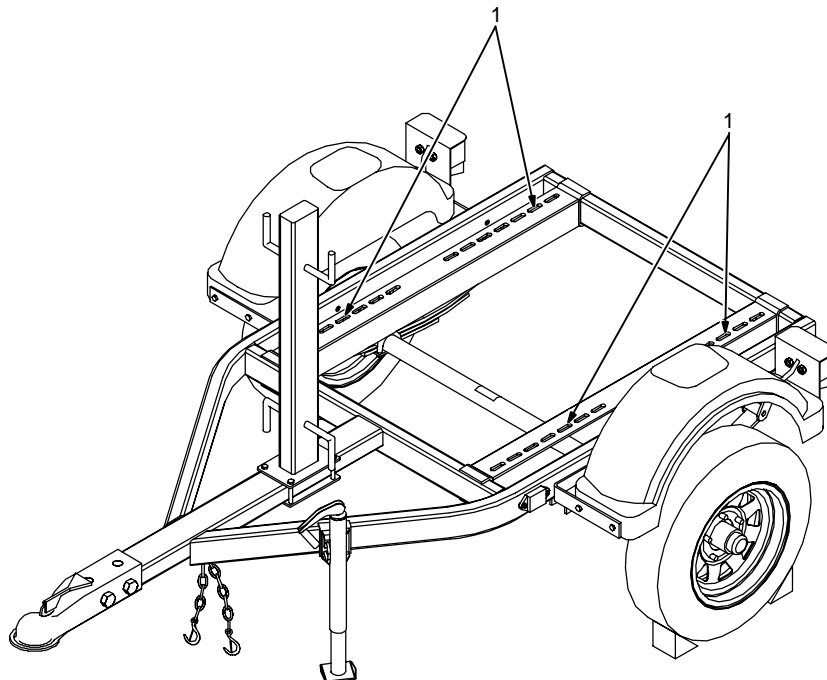
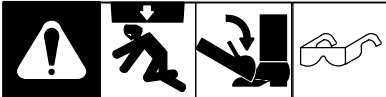

▲ Use equipment of adequate capacity to lift the generator.

▲ Support front of trailer with jack. Support rear of trailer with blocks. Block wheels.

▲ If trailer is not installed on vehicle, use trailer jack to obtain desired height and to support tongue weight while installing welding generator.

▲ Install welding generator on trailer with engine end toward hitch end of trailer.

▲ Distribute weight so trailer tongue weight is approximately 10% of gross trailer weight.

 Use hardware in yellow bag to mount welding generator.

 The axle has a slight camber (arch) to help the tires wear properly when the trailer is loaded. With no load on the trailer the tires appear to tilt outward. When the trailer is loaded, the tires straighten out and wear evenly.

1 Crossmember Mounting Holes

Use supplied hardware to install generator so front panel faces rear.

Move crossmembers to correct position on trailer frame so mounting holes align with welding generator holes. Crossmembers should be adjusted so tongue weight is 10 – 15% of gross trailer weight.

Tighten crossmembers and secure generator.

Tools Needed:



1/2, 9/16 in

ST-802 067-B

3-7. Maintenance

NOTE

Do not use trailer if any part is damaged or not working properly. When performing maintenance, check trailer for worn, damaged, or non-working parts. Check for free rotation of assemblies mounted on bushings or bearings.

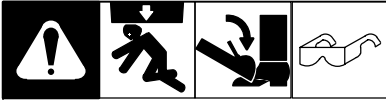

 Replace trailer hardware only with SAE hardware of same grade, type and size as originally installed.

▲ Support trailer with jack. Block wheels.

▲ Do not put any body part under trailer while lifting or performing maintenance.

Once a year, lubricate all moving parts on trailer with SAE 20W oil. Lubricate more often if trailer is exposed to elements or subject to frequent off-road use.

1 Wheel Bearings

Every 12,000 miles, check wheel bearings. Repack bearings if necessary using a good quality lithium-based extreme pressure grease.

When reinstalling wheels, be sure wheel nuts are properly tightened (see Trailer Towing Safety Precautions at beginning of manual).

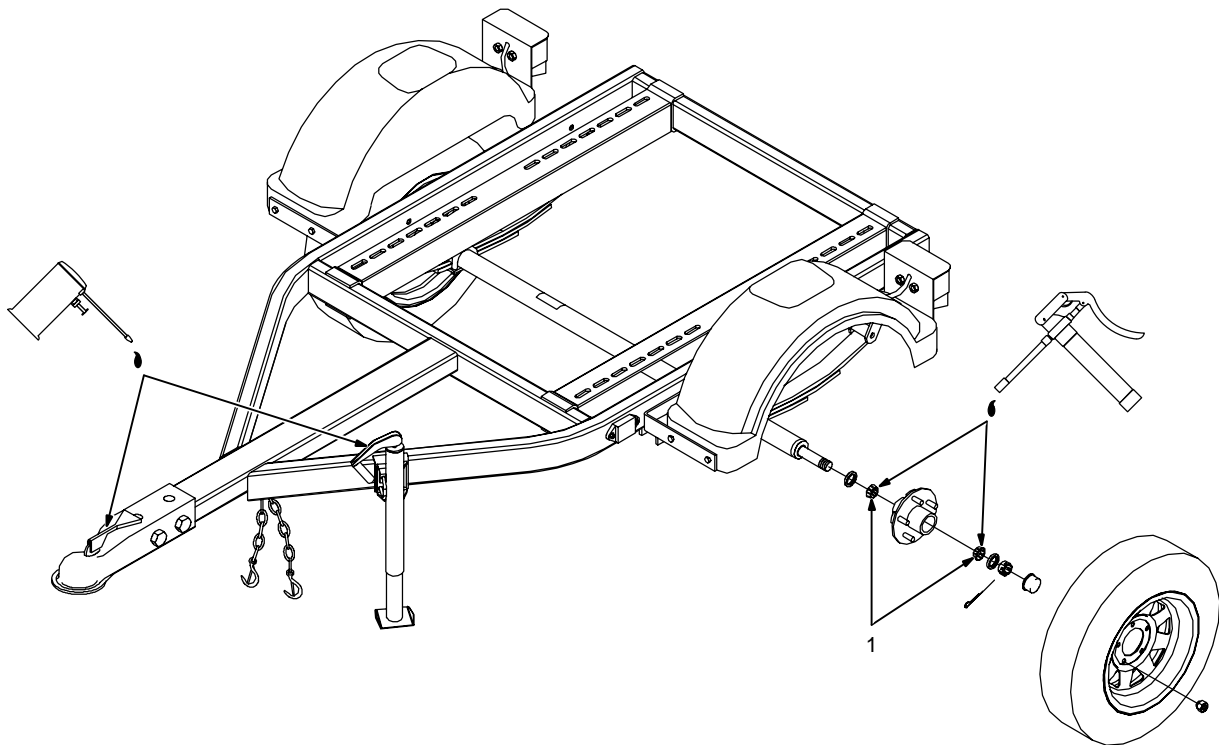

Tools Needed:

 13/16, 1-1/2 in

ST-802 075-B

3-8. Torquing Wheel Bearings

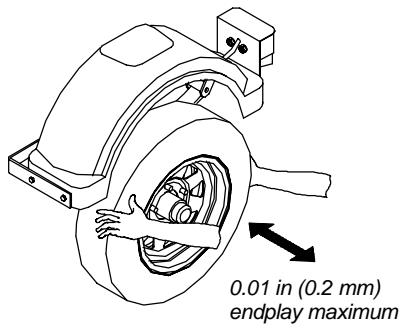
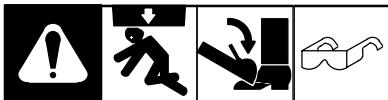

Check hub endplay. If loose, remove wheel and go to next step.

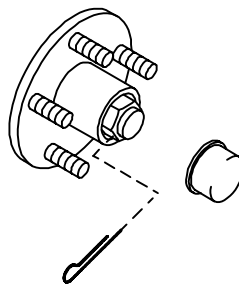

Remove cap and cotter pin.

▲ **Loss of control hazard.** To prevent injury and damage, check and repack wheel bearings once a year or every 12,000 miles (19,500 km), whichever comes first.

▲ **Use proper equipment to lift and support unit.**

▲ **Do not put any body part under trailer while lifting or performing maintenance.**

☞ *Torque wheel bearings whenever hub nut is removed or hub is too loose.*

Repack bearings according to Section 3-7.

Tools Needed:

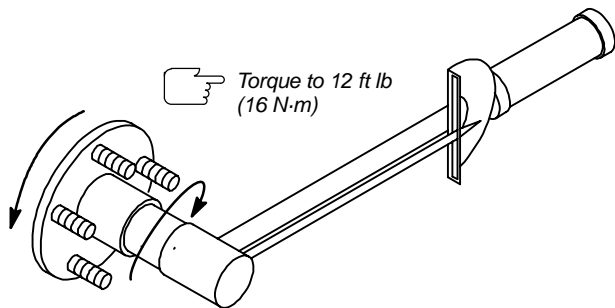
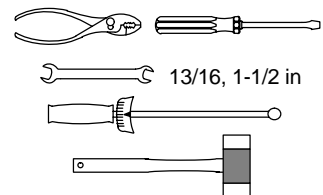

Torque nut while turning hub forward.

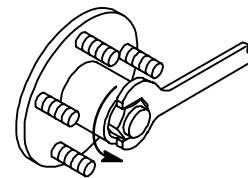

Turn nut until "just loose."

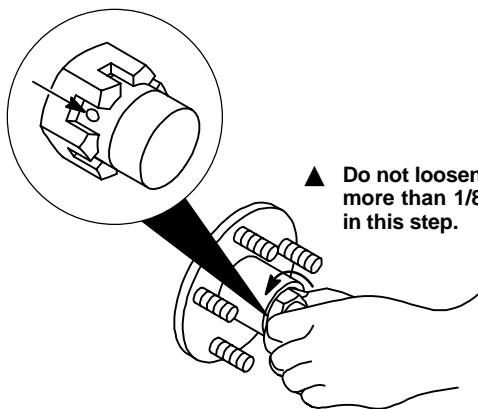

Further loosen nut until first slot in nut aligns with hole in spindle.

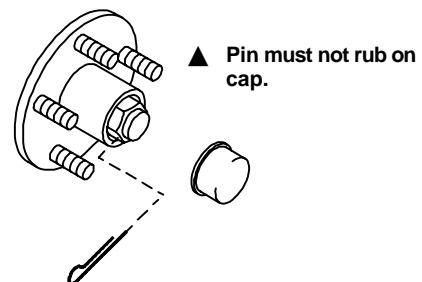

Install new cotter pin and bend ends around nut. Install cap. Install wheel (See Safety Precautions) and recheck endplay.

Ref. ST-800 441-B

SECTION 4 – PARTS LIST

 Hardware is common and not available unless listed.

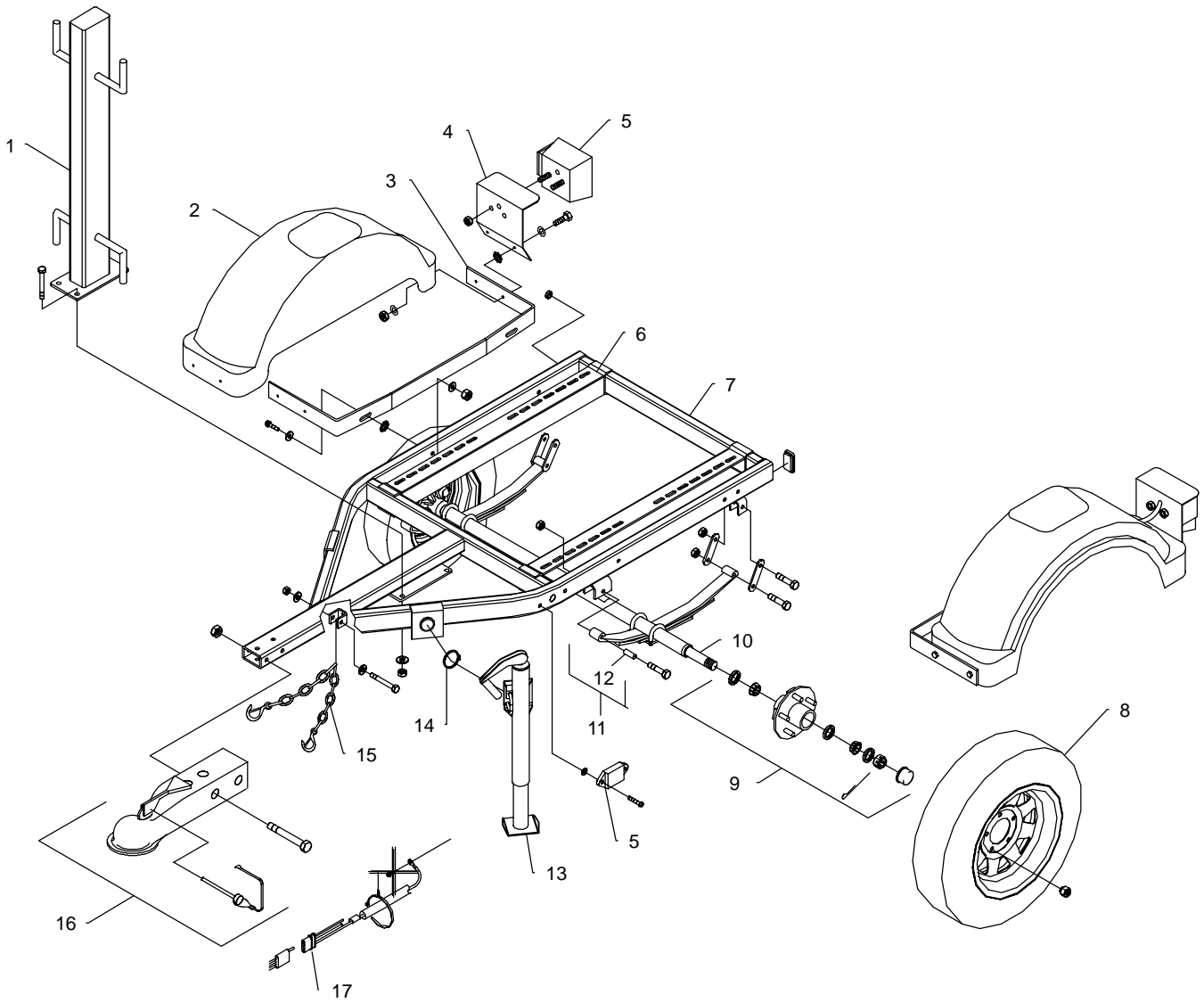

ST-802 076-B

Figure 4-1. Complete Assembly

Item No.	Part No.	Description	Quantity
Figure 4-1. Complete Assembly			
... 1	◆043 826	CABLE TREE (includes mounting hardware)	1
... 2	189 594	FENDER	2
...	189 581	FENDER, hardware kit	1
... 3	189 595	FENDER, mtg bracket	2
... 4	189 582	GUARD, light	2
... 5	189 577	LIGHT KIT (includes wiring harness)	1
... 6	189 597	SLIDE, crossmember	2
... 7	189 596	DECK	1
...	189 693	MOUNTING HARDWARE KIT	1
... 8	189 591	TIRE, 4.80-12 (includes rim)	2
... 9	189 593	HUB, axle #3 (consisting of)	2
...	091 991	CAP, grease	1
...	190 760	SEAL, grease	2
...	190 762	BEARING	2
...	190 761	RACE, bearing	2
...	190 759	HOUSING, hub axle	1
...	167 787	KIT, bearing (for one wheel – includes bearings, cups, grease cap, grease seal, and key)	1
... 10	189 592	AXLE, #3 (includes hub – does not include leaf springs and hardware)	1
...	189 579	AXLE, parts bag (includes red bag hardware)	1
... 11	198 546	SPRING, leaf (includes the following)	2
... 12	088 870	BUSHING, nylon	2
... 13	189 586	JACK, screw w/pad	1
... 14	189 587	JACK, ret ring	1
... 15	199 860	CHAIN, safety	1
... 16	189 585	HITCH, ball 2.000	1
... 16	◆043 824	LUNETTE EYE	1
... 16	◆043 825	CLEVIS HITCH	1
... 17	191 267	HARNESS, trailer (also included in item 5 – light kit)	1

◆OPTIONAL

To maintain the factory original performance of your equipment, use only Manufacturer's Suggested Replacement Parts. Model and serial number required when ordering parts from your local distributor.

TRUE BLUE[®]

WARRANTY

Effective January 1, 2000

(Equipment with a serial number preface of "LA" or newer)

This limited warranty supersedes all previous Miller warranties and is exclusive with no other guarantees or warranties expressed or implied.

Warranty Questions?

Call
1-800-4-A-MILLER
for your local
Miller distributor.

Your distributor also gives
you ...

Service

You always get the fast,
reliable response you
need. Most replacement
parts can be in your
hands in 24 hours.

Support

Need fast answers to the
tough welding questions?
Contact your distributor.
The expertise of the
distributor and Miller is
there to help you, every
step of the way.

LIMITED WARRANTY – Subject to the terms and conditions below, Miller Electric Mfg. Co., Appleton, Wisconsin, warrants to its original retail purchaser that new Miller equipment sold after the effective date of this limited warranty is free of defects in material and workmanship at the time it is shipped by Miller. THIS WARRANTY IS EXPRESSLY IN LIEU OF ALL OTHER WARRANTIES, EXPRESS OR IMPLIED, INCLUDING THE WARRANTIES OF MERCHANTABILITY AND FITNESS.

Within the warranty periods listed below, Miller will repair or replace any warranted parts or components that fail due to such defects in material or workmanship. Miller must be notified in writing within thirty (30) days of such defect or failure, at which time Miller will provide instructions on the warranty claim procedures to be followed.

Miller shall honor warranty claims on warranted equipment listed below in the event of such a failure within the warranty time periods. All warranty time periods start on the date that the equipment was delivered to the original retail purchaser, or one year after the equipment is sent to a North American distributor or eighteen months after the equipment is sent to an International distributor.

1. 5 Years Parts – 3 Years Labor
 - * Original main power rectifiers
 - * Inverters (input and output rectifiers only)
2. 3 Years — Parts and Labor
 - * Transformer/Rectifier Power Sources
 - * Plasma Arc Cutting Power Sources
 - * Semi-Automatic and Automatic Wire Feeders
 - * Inverter Power Supplies
 - * Intelligig
 - * Engine Driven Welding Generators
(NOTE: Engines are warranted separately by the engine manufacturer.)
3. 1 Year — Parts and Labor
 - * DS-2 Wire Feeder
 - * Motor Driven Guns (w/exception of Spoolmate 185 & Spoolmate 250)
 - * Process Controllers
 - * Positioners and Controllers
 - * Automatic Motion Devices
 - * RFCS Foot Controls
 - * Induction Heating Power Sources
 - * Water Coolant Systems
 - * HF Units
 - * Grids
 - * Maxstar 140
 - * Spot Welders
 - * Load Banks
 - * Miller Cyclomatic Equipment
 - * Running Gear/Trailers
 - * Plasma Cutting Torches (except APT & SAF Models)
 - * Field Options
(NOTE: Field options are covered under True Blue[®] for the remaining warranty period of the product they are installed in, or for a minimum of one year — whichever is greater.)
4. 6 Months — Batteries
5. 90 Days — Parts
 - * MIG Guns/TIG Torches
 - * Induction Heating Coils and Blankets

- * APT, ZIPCUT & PLAZCUT Model Plasma Cutting Torches
- * Remote Controls
- * Accessory Kits
- * Replacement Parts (No labor)
- * Spoolmate 185 & Spoolmate 250
- * Canvas Covers

Miller's True Blue[®] Limited Warranty shall not apply to:

1. **Consumable components; such as contact tips, cutting nozzles, contactors, brushes, slip rings, relays or parts that fail due to normal wear.**
2. Items furnished by Miller, but manufactured by others, such as engines or trade accessories. These items are covered by the manufacturer's warranty, if any.
3. Equipment that has been modified by any party other than Miller, or equipment that has been improperly installed, improperly operated or misused based upon industry standards, or equipment which has not had reasonable and necessary maintenance, or equipment which has been used for operation outside of the specifications for the equipment.

MILLER PRODUCTS ARE INTENDED FOR PURCHASE AND USE BY COMMERCIAL/INDUSTRIAL USERS AND PERSONS TRAINED AND EXPERIENCED IN THE USE AND MAINTENANCE OF WELDING EQUIPMENT.

In the event of a warranty claim covered by this warranty, the exclusive remedies shall be, at Miller's option: (1) repair; or (2) replacement; or, where authorized in writing by Miller in appropriate cases, (3) the reasonable cost of repair or replacement at an authorized Miller service station; or (4) payment of or credit for the purchase price (less reasonable depreciation based upon actual use) upon return of the goods at customer's risk and expense. Miller's option of repair or replacement will be F.O.B., Factory at Appleton, Wisconsin, or F.O.B. at a Miller authorized service facility as determined by Miller. Therefore no compensation or reimbursement for transportation costs of any kind will be allowed.

TO THE EXTENT PERMITTED BY LAW, THE REMEDIES PROVIDED HEREIN ARE THE SOLE AND EXCLUSIVE REMEDIES. IN NO EVENT SHALL MILLER BE LIABLE FOR DIRECT, INDIRECT, SPECIAL, INCIDENTAL OR CONSEQUENTIAL DAMAGES (INCLUDING LOSS OF PROFIT), WHETHER BASED ON CONTRACT, TORT OR ANY OTHER LEGAL THEORY.

ANY EXPRESS WARRANTY NOT PROVIDED HEREIN AND ANY IMPLIED WARRANTY, GUARANTY OR REPRESENTATION AS TO PERFORMANCE, AND ANY REMEDY FOR BREACH OF CONTRACT TORT OR ANY OTHER LEGAL THEORY WHICH, BUT FOR THIS PROVISION, MIGHT ARISE BY IMPLICATION, OPERATION OF LAW, CUSTOM OF TRADE OR COURSE OF DEALING, INCLUDING ANY IMPLIED WARRANTY OF MERCHANTABILITY OR FITNESS FOR PARTICULAR PURPOSE, WITH RESPECT TO ANY AND ALL EQUIPMENT FURNISHED BY MILLER IS EXCLUDED AND DISCLAIMED BY MILLER.

Some states in the U.S.A. do not allow limitations of how long an implied warranty lasts, or the exclusion of incidental, indirect, special or consequential damages, so the above limitation or exclusion may not apply to you. This warranty provides specific legal rights, and other rights may be available, but may vary from state to state.

In Canada, legislation in some provinces provides for certain additional warranties or remedies other than as stated herein, and to the extent that they may not be waived, the limitations and exclusions set out above may not apply. This Limited Warranty provides specific legal rights, and other rights may be available, but may vary from province to province.





Owner's Record

Please complete and retain with your personal records.

Model Name	Serial/Style Number
Purchase Date	(Date which equipment was delivered to original customer.)
Distributor	
Address	
City	
State	Zip



For Service

Call 1-800-4-A-Miller or see our website at www.MillerWelds.com to locate a DISTRIBUTOR or SERVICE AGENCY near you.

Always provide Model Name and Serial/Style Number.

Contact your Distributor for:

- Welding Supplies and Consumables
- Options and Accessories
- Personal Safety Equipment
- Service and Repair
- Replacement Parts
- Training (Schools, Videos, Books)
- Technical Manuals (Servicing Information and Parts)
- Circuit Diagrams
- Welding Process Handbooks

Contact the Delivering Carrier for:

File a claim for loss or damage during shipment.

For assistance in filing or settling claims, contact your distributor and/or equipment manufacturer's Transportation Department.

Miller Electric Mfg. Co.

An Illinois Tool Works Company
1635 West Spencer Street
Appleton, WI 54914 USA

International Headquarters—USA

USA Phone: 920-735-4505 Auto-Attended
USA & Canada FAX: 920-735-4134
International FAX: 920-735-4125

European Headquarters – United Kingdom

Phone: 44 (0) 1204-593493
FAX: 44 (0) 1204-598066

www.MillerWelds.com

